

In the interest of continuous improvement and upgrade of our products Hörtig reserves the right to change the technical specifications at any time, without prior notice.

The examples given (for reference only) apply to a concrete wall

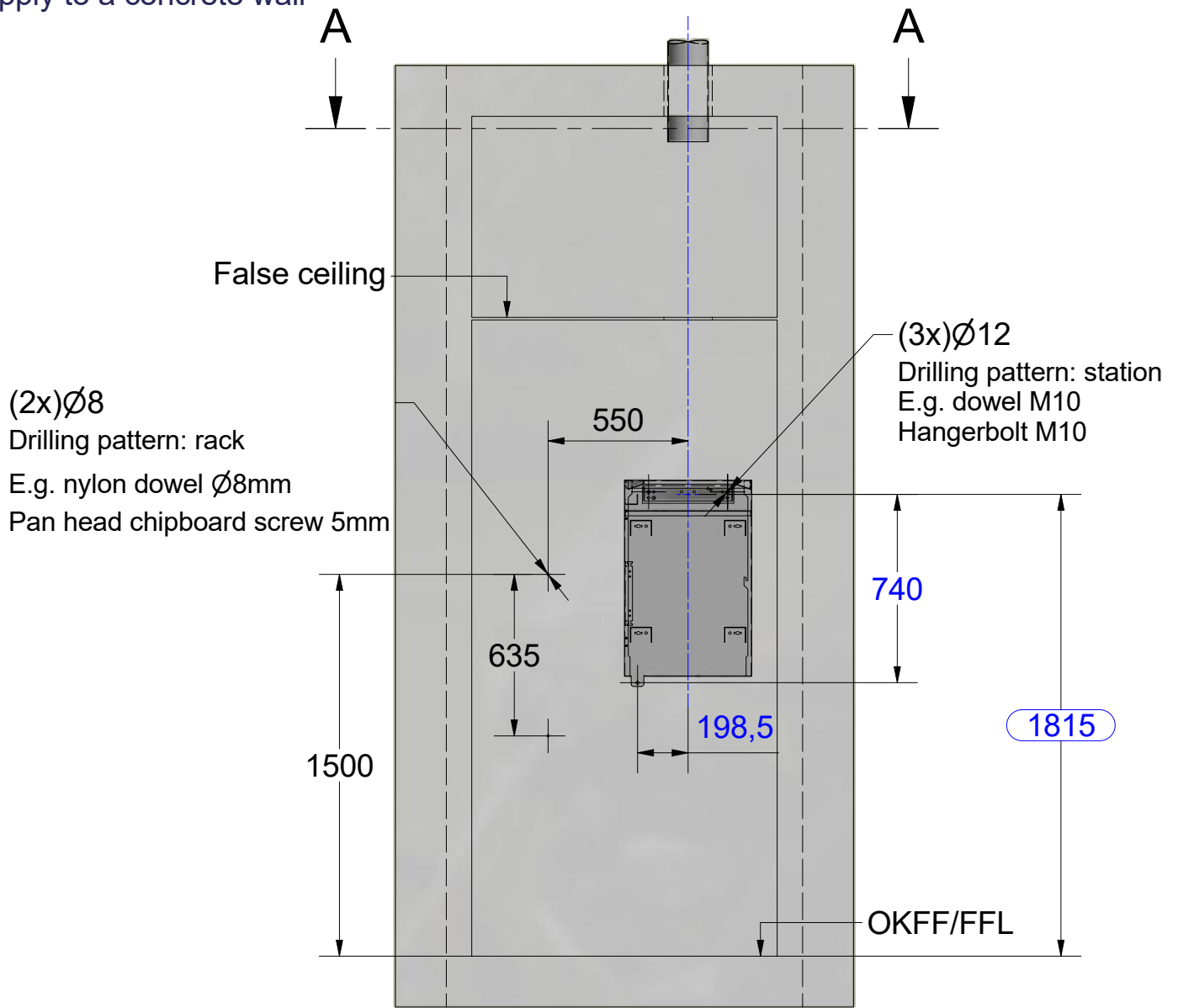

A-A (1 : 25)

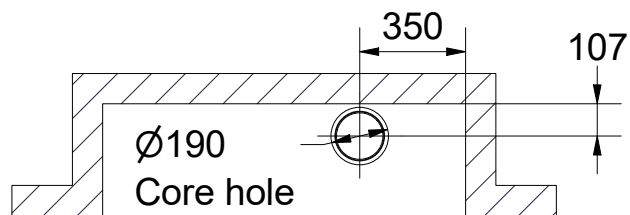

(1 : 5)

1.0461.T.45 Wall bracket with alternative fixation holes: use at least two.

