

Blower 3-phase

1.2186.3.0B - 3kW-5kW
 1.2187.3.0B - 4kW-7kW

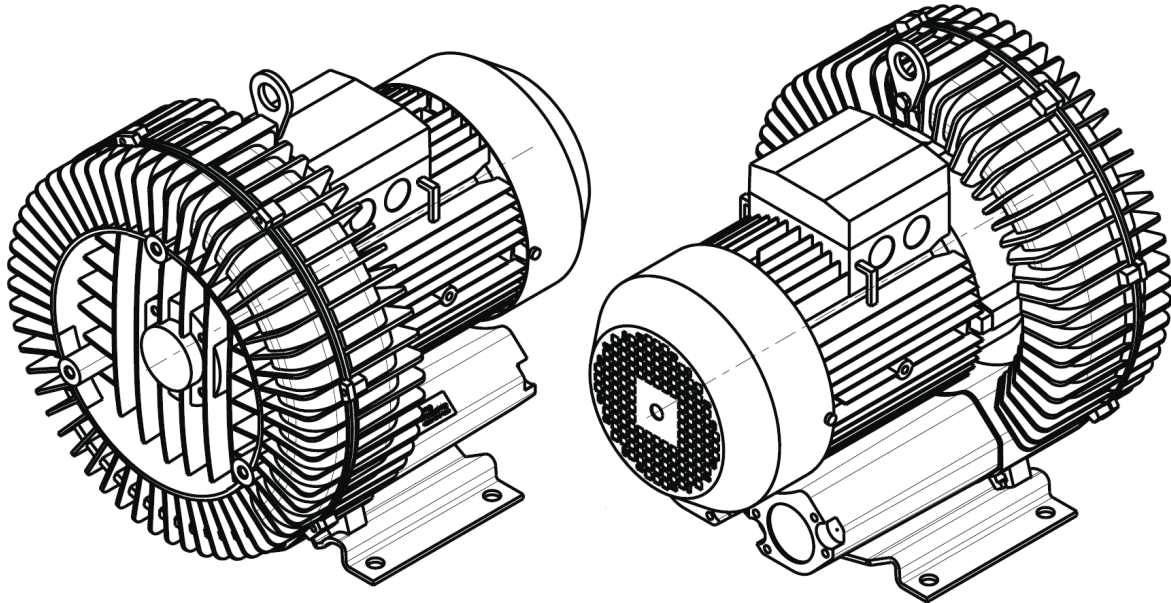

<p>Power ratings</p> <p>Material: Aluminium Motor: IE2, 3-phase, 400 V Frequency range: 50-87 Hz Housing: IP55 Turns: 3000-5000 min⁻¹ Termosensors: 3 inbuild for VSD operation Weight: 34 kg (3 kW) 43 kg (4 kW) Flange: Hose type 60 mm Noise: 70 dB(A) @ 50 Hz</p>	<p>Power ratings</p> <table border="1"> <thead> <tr> <th rowspan="2">freq [Hz]</th> <th colspan="2">power [W]</th> </tr> <tr> <th>3 kW</th> <th>4 kW</th> </tr> </thead> <tbody> <tr> <td>50</td> <td>3.0</td> <td>4.0</td> </tr> <tr> <td>60</td> <td>3.6</td> <td>4.8</td> </tr> <tr> <td>87</td> <td>5.2</td> <td>7.0</td> </tr> </tbody> </table> <p>Note: we recommend VSD to be 20% over motor power</p>	freq [Hz]	power [W]		3 kW	4 kW	50	3.0	4.0	60	3.6	4.8	87	5.2	7.0
freq [Hz]	power [W]														
	3 kW	4 kW													
50	3.0	4.0													
60	3.6	4.8													
87	5.2	7.0													

Typical speeds:									
Tube DN	length [m]	weight [kg]	freq [Hz]	speed [m/s]		freq [Hz]	speed [m/s]		
				3 kW	4 kW		3 kW	4 kW	
110	200	3	50	10.0	12.0	87	17.4	20.9	
110	1,000	15	50	6.4	7.6	87	11.1	13.2	
160	200	3	50	5.7	7.0	87	9.9	12.2	
160	200	5	50	5.6	6.9	87	9.7	12.0	
160	500	25	50	4.3	5.3	87	7.5	9.2	
160	1,000	25	50	3.6	4.4	87	6.3	7.7	