

Blower 3-phase

1.2182.2.0B
 1.3 kW - 2.1 kW

64 dB (A)

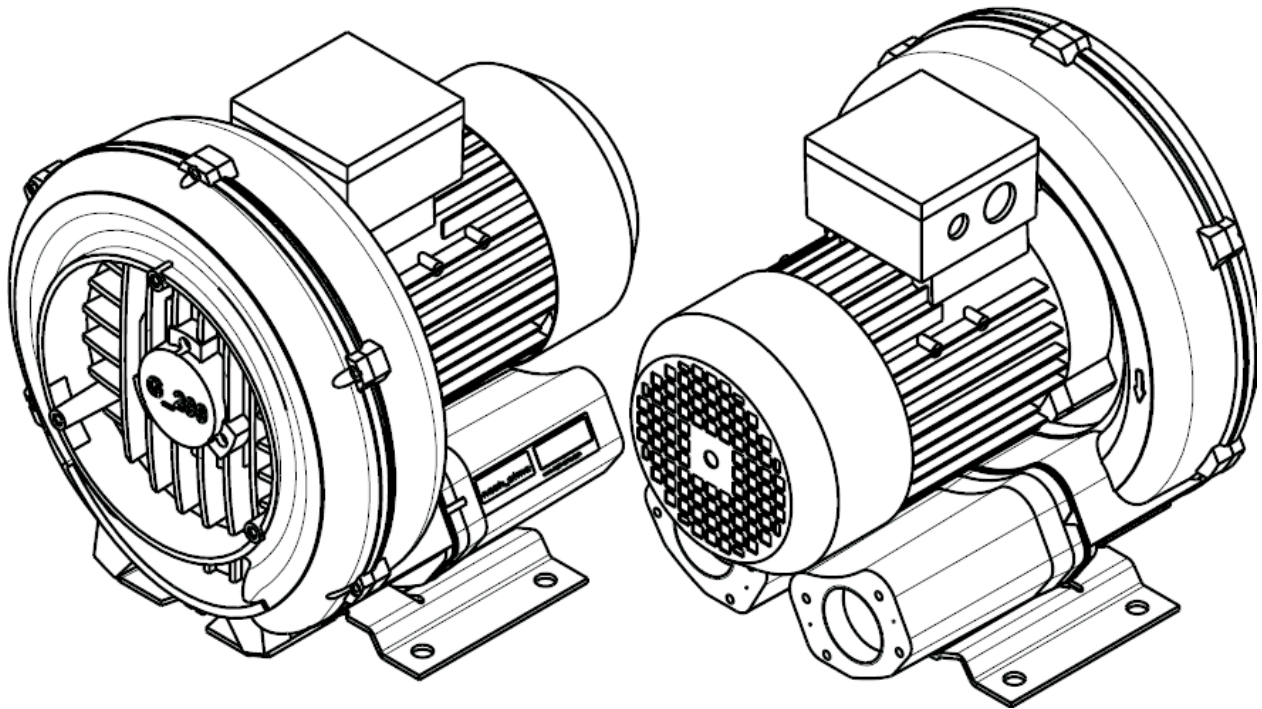

Blower 3-phase

<p>Power ratings</p> <p>Material: Aluminium Motor: IE2, 3-phase Frequency range: 50-87 Hz Housing: IP55 Turns: 3000-5000 min⁻¹ Thermosensors: 3 inbuild for VSD operation Weight: 21 kg Flange: Hose type 60 mm Noise: 64 dB(A) @ 50 Hz</p>	<p>Power ratings</p> <table border="1" style="margin-left: auto; margin-right: auto;"> <tr> <th>freq</th> <th>power</th> </tr> <tr> <td>50 Hz</td> <td>1.3 kW</td> </tr> <tr> <td>60 Hz</td> <td>1.5 kW</td> </tr> <tr> <td>87 Hz</td> <td>2.1 kW</td> </tr> </table> <p>Note: we recommend VSD to be 20% over motor power</p>	freq	power	50 Hz	1.3 kW	60 Hz	1.5 kW	87 Hz	2.1 kW
freq	power								
50 Hz	1.3 kW								
60 Hz	1.5 kW								
87 Hz	2.1 kW								

Typical speeds:

Tube DN	length [m]	weight [kg]	freq [Hz]	speed [m/s]
110	100	2	50	4.3
110	200	2	50	4.0
110	400	2	50	3.4
110	400	1	50	3.9
110	400	1	64	5.0
110	400	1	87	6.8